



STANDARD PRODUCT RANGE

FRIALIT®-DEGUSSIT® High Performance Ceramics

www.friatec-ceramics.com

CONTACT

Marc Lerenard

Phone: +33 (0)1 85 78 38 04

E-mail: marc.lerenard@eu.unicore.com

MATERIALS

Material	FRIATEC-Brand	Characterisation
Al ₂ O ₃ Aluminium Oxide	DEGUSSIT AL23	Pure Al ₂ O ₃ , dense, excellent thermal and electrical resistance properties, corrosion resistant, permeable to microwaves
Al ₂ O ₃ Aluminium Oxide	DEGUSSIT AL24	Pure Al ₂ O ₃ , slightly porous, good resistance to thermal shock, extremely good creep strength
Al ₂ O ₃ Aluminium Oxide	DEGUSSIT AL25	Pure Al ₂ O ₃ , very porous, good thermal insulation, highest resistance to thermal shock of all the Al ₂ O ₃ materials
Al ₂ O ₃ Aluminium Oxide	DEGUSSIT DD57	Pure Al ₂ O ₃ , dense, without any binder, red colour, wear resistant and tough, also called 'sintered ruby'
Al ₂ O ₃ Aluminium Oxide	FRIALIT F99,7	Pure Al ₂ O ₃ , dense, extremely resistant to wear and corrosion, very high electrical insulating properties
Al ₂ O ₃ (+ ZrO ₂) Aluminium Oxide, fine grain stabilized	FRIALIT FZT	Al ₂ O ₃ toughened with ZrO ₂ , dense, high strength, good resistance to thermal shock, extremely resistant to wear and corrosion, fine grain size
ZrO ₂ Zirkonium Oxide	FRIALIT FZM	ZrO ₂ partially stabilized with MgO, dense, high strength and highly wear resistant, extremely resistant to corrosion and thermal shock
ZrO ₂ Zirkonium Oxide	DEGUSSIT FZY	Partially stabilized with Y ₂ O ₃ , dense, high purity ZrO ₂ , high temperature and corrosion resistance, ion conducting for measuring oxygen

On request, we also supply parts with dimensions not listed as well as parts made of other ceramic materials

TOLERANCES IN HIGH-TEMPERATURE TECHNOLOGY

The dimensional accuracy of the size of the sintered parts essentially depends on the material and the forming method.

Tubes, multi-bore tubes and rods $\varnothing \geq 3$ mm as well as bands:

Diameter $\pm 5\%$ (but not less than $\pm 0,1$ mm); Cut length tolerance: $\pm 1\%$, < 100 mm upon request;
Straightness: maximum crescent height 0.5% of total length

Tubes, multi-bore tubes and rods $\varnothing < 3$ mm:

Diameter $\pm 5\%$ (but not less than $\pm 0,05$ mm); Cut length tolerance: $\pm 1\%$, < 100 mm upon request;
Straightness: maximum crescent height: 0.5% of total length

Crucibles, boats, combustion trays:

Tolerances $\pm 3\%$ (but not less $\pm 0,1$ mm)

Plates:

Tolerances $\pm 3\%$ (but not less $\pm 0,1$ mm); Deflection: maximum 0,5 % of the diagonal

Insulating beads and grinding bodies:

Tolerances $\pm 3\%$ (but not less than $\pm 0,1$ mm)

All dimensions in mm

TABLE OF CONTENTS

Surface Finishing

Pages:

06-10 Fine Grinding tools

11 Burnishing wheels





SURFACE **FINISHING**

Fine Grinding Tools, Burnishing Wheels

FINE-GRINDING TOOL - BENCHSTONE

DEGUSSIT DD57
DEGUSSIT AL24

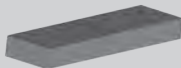

Dimensions (mm)	Colour	Type	Product No. DEGUSSIT DD57
100 x 25 x 10	ruby red	fine	901-41100-0
100 x 25 x 10	ruby red	medium	902-41100-0
150 x 25 x 15	ruby red	fine	901-41101-0
150 x 25 x 15	ruby red	medium	902-41101-0
200 x 50 x 12	ruby red	fine	901-41102-0
200 x 50 x 12	ruby red	medium	902-41102-0

Dimensions (mm)	Colour	Type	Product No. DEGUSSIT AL24
100 x 25 x 10	white	coarse	903-21100-0
150 x 25 x 15	white	coarse	903-21101-0

FINE-GRINDING TOOL - BENCHSTONE IN WOODEN CASE, REMOVABLE

DEGUSSIT DD57
DEGUSSIT AL24

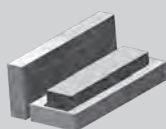

Dimensions (mm)	Colour	Type	Product No.
120 x 50 x 10	ruby red	fine / medium	904-41111-0

FINE-GRINDING TOOL - BENCHSTONE IN WOODEN CASE, GLUED IN

DEGUSSIT DD57
DEGUSSIT AL24

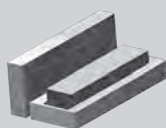

Dimensions (mm)	Colour	Type	Product No. DEGUSSIT DD57
100 x 25 x 10	ruby red	fine	901-41110-0
100 x 25 x 10	ruby red	medium	902-41110-0
120 x 50 x 10	ruby red	fine	901-41111-0
120 x 50 x 10	ruby red	medium	902-41111-0
200 x 50 x 12	ruby red	fine	901-41112-0
200 x 50 x 12	ruby red	medium	902-41112-0

Dimensions (mm)	Colour	Type	Product No. DEGUSSIT AL24
100 x 25 x 10	white	coarse	903-21110-0

FINE-GRINDING TOOL - TRIANGULAR

DEGUSSIT DD57

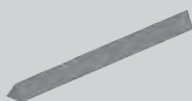

Dimensions (mm)	Colour	Type	Product No.
100 x 4	ruby red	fine	901-41200-0
100 x 4	ruby red	medium	902-41200-0
100 x 6	ruby red	fine	901-41201-0
100 x 6	ruby red	medium	902-41201-0
100 x 6	ruby red	coarse	903-44201-0
100 x 8	ruby red	fine	901-41202-0
100 x 8	ruby red	medium	902-41202-0
100 x 8	ruby red	coarse	903-44202-0
100 x 10	ruby red	fine	901-41203-0
100 x 10	ruby red	medium	902-41203-0
100 x 10	ruby red	coarse	903-44203-0
120 x 13	ruby red	fine	901-41205-0
120 x 13	ruby red	medium	902-41205-0
120 x 13	ruby red	coarse	903-44205-0

FINE-GRINDING TOOL - RECTANGULAR

Dimensions (mm)	Colour	Type	Product No.
100 x 6 x 3	ruby red	fine	901-41220-0
100 x 6 x 3	ruby red	medium	902-41220-0
100 x 8 x 6	ruby red	fine	901-41221-0
100 x 8 x 6	ruby red	medium	902-41221-0
100 x 8 x 6	ruby red	coarse	903-44221-0

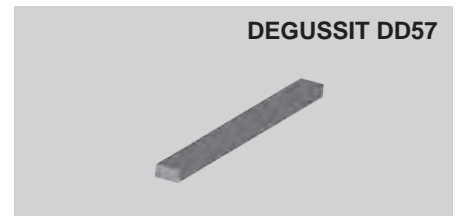

FINE-GRINDING TOOL - SQUARE

Dimensions (mm)	Colour	Type	Product No.
100 x 4	ruby red	fine	901-41210-0
100 x 4	ruby red	medium	902-41210-0
100 x 6	ruby red	fine	901-41211-0
100 x 6	ruby red	medium	902-41211-0
100 x 6	ruby red	coarse	903-44211-0
100 x 8	ruby red	fine	901-41212-0
100 x 8	ruby red	medium	902-41212-0
100 x 8	ruby red	coarse	903-44212-0
100 x 10	ruby red	fine	901-41213-0
100 x 10	ruby red	medium	902-41213-0
100 x 10	ruby red	coarse	903-44213-0
120 x 13	ruby red	fine	901-41214-0
120 x 13	ruby red	medium	902-41214-0
120 x 13	ruby red	coarse	903-44214-0

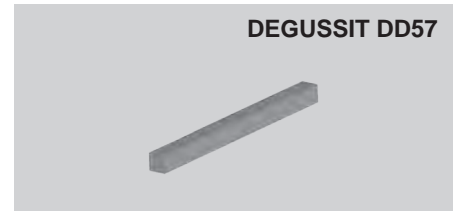

FINE-GRINDING TOOL - SEMI-CIRCULAR

Dimensions (mm)	Colour	Type	Product No.
100 x 10	ruby red	medium	902-41231-0
100 x 10	ruby red	coarse	903-44231-0



FINE-GRINDING TOOL - CIRCULAR

Dimensions (mm)	Colour	Type	Product No.
100 x 4	ruby red	fine	901-41270-0
100 x 4	ruby red	medium	902-41270-0
100 x 6	ruby red	fine	901-41271-0
100 x 6	ruby red	medium	902-41271-0
100 x 6	ruby red	coarse	903-44271-0
100 x 8	ruby red	fine	901-41272-0
100 x 8	ruby red	medium	902-41272-0
100 x 8	ruby red	coarse	903-44272-0
100 x 10	ruby red	fine	901-41273-0
100 x 10	ruby red	medium	902-41273-0
100 x 10	ruby red	coarse	903-44273-0



ASSORTMENT OF FILES

DEGUSSIT DD57



	Dimensions (mm)	Colour	Type	Product No.
			Assortment	900-00700-0
▲	100 x 10	ruby red	medium	902-41203-0
■	100 x 10	ruby red	medium	902-41213-0
■	100 x 8 x 6	ruby red	coarse	903-44221-0
●	100 x 6	ruby red	medium	902-41271-0
◐	100 x 10	ruby red	coarse	903-44231-0

The Files are also available separately

ASSORTMENT OF FILES - MIDGET FILES

DEGUSSIT DD57



	Dimensions (mm)	Colour	Type	PU pcs.	Product No.
			Assortment		900-41420-0
▲	50 x 2	ruby red	fine	20	901-41402-0
▲	100 x 3	ruby red	fine	10	901-41413-0
■	50 x 1	ruby red	fine	20	901-41400-0
■	100 x 2	ruby red	fine	10	901-41403-0
■	50 x 3 x 0,3	ruby red	fine	20	901-41406-0
●	50 x 1	ruby red	fine	20	901-41401-0
●	100 x 2	ruby red	fine	10	901-41404-0
●	100 x 3	ruby red	fine	10	901-41405-0
◐	100 x 4	ruby red	fine	10	901-41407-0
▲	100 x 5 x 1,5	ruby red	fine	10	901-41409-0
●	100 x 4 x 1,5	ruby red	fine	10	901-41411-0

The files are also available separately

FINE-GRINDING TOOL - BLADE

Dimensions (mm)	Colour	Type	Product No.
100 x 15 x 3/0,5	ruby red	fine	901-41291-0
100 x 15 x 3/0,5	ruby red	medium	902-41291-0

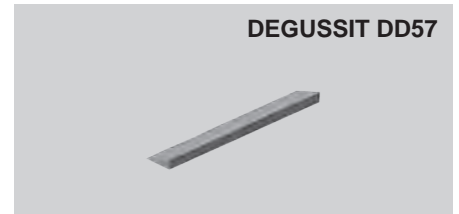

FINE-GRINDING TOOL - TAPERED

Dimensions (mm)	Colour	Type	Product No.
100 x 30 x 7/2	ruby red	medium	902-41105-0



FINE-GRINDING TOOL - RHOMBOID

Dimensions (mm)	Colour	Type	Product No.
100 x 13 x 5	ruby red	coarse	903-44240-0

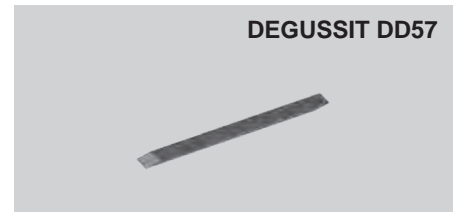

FINE-GRINDING TOOL - CONICAL

Dimensions (mm)	Colour	Type	Product No.
100 x 5 x 2	ruby red	fine	901-41255-0
100 x 5 x 2	ruby red	coarse	903-44255-0



FINE-GRINDING TOOL - PENCIL

Dimensions (mm)	Colour	Type	Product No.
100 x 5	ruby red	fine	901-41261-0



FINE-GRINDING TOOL - MOUNTED POINT, CYLINDRICAL

DEGUSSIT DD57

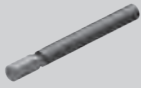

H	Ø D	Ø d	Type	Product No.
4	2	2,35	fine	921-41002-1
4	2	3	fine	921-41002-0
6	3	2,35	fine	921-41003-1
6	3	3	fine	921-41003-0
8	4	2,35	fine	921-41104-1
8	4	3	fine	921-41104-0
10	5	3	fine	921-41110-0
12	6	6	fine	921-41116-0
10	8	6	fine	921-41128-0
16	8	6	fine	921-41136-0
12	10	6	fine	921-41150-0
4	2	2,35	medium	922-44002-1
4	2	3	medium	922-44002-0
6	3	2,35	medium	922-44003-1
6	3	3	medium	922-44003-0
8	4	2,35	medium	922-44104-1
8	4	3	medium	922-44104-0
10	5	3	medium	922-44110-0
12	6	6	medium	922-44116-0
10	8	6	medium	922-44128-0
16	8	6	medium	922-44136-0
12	10	6	medium	922-44150-0
Order-Related Product				

FINE-GRINDING TOOL - MOUNTED POINT, CYLINDRICAL-CONICAL

DEGUSSIT DD57

point angle 60°



H	Ø D	Ø d	Type	Product No.
8	4	2,35	fine	921-41204-1
8	4	3	fine	921-41204-0
10	5	3	fine	921-41210-0
12	6	6	fine	921-41216-0
16	8	6	fine	921-41236-0
20	10	6	fine	921-41255-0
8	4	2,35	medium	922-44204-1
8	4	3	medium	922-44204-0
10	5	3	medium	922-44210-0
12	6	6	medium	922-44216-0
16	8	6	medium	922-44236-0
20	10	6	medium	922-44255-0
Order-Related Product				

FINE-GRINDING WHEELS

B	Ø D	Ø d	Design	Product No.
3	75	20	with metal bushing	911-41373-0
4	75	20	with metal bushing	911-41374-0
6	75	20	with metal bushing	911-41376-0
8	75	20	with metal bushing	911-41378-0
10	75	20	with metal bushing	911-41380-0
8	100	32	with metal bushing	911-41488-0
10	100	32	with metal bushing	911-41490-0
3	75	30	without metal bushing	911-41373-7
4	75	30	without metal bushing	911-41374-7
6	75	30	without metal bushing	911-41376-7
8	75	30	without metal bushing	911-41378-7
10	75	30	without metal bushing	911-41380-7
8	100	42	without metal bushing	911-41488-7
10	100	42	without metal bushing	911-41490-7

Order-Related Product

Profile 2 and 3 upon request

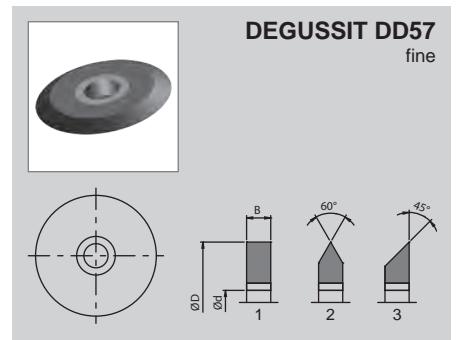

BURNISHING WHEELS

Ø D1	Ø D2	Ø D3	a	Product No.
62	42	10	3	931-41906-1
62	42	10	4	931-41906-2
62	42	10	6	931-41906-3

Order-Related Product

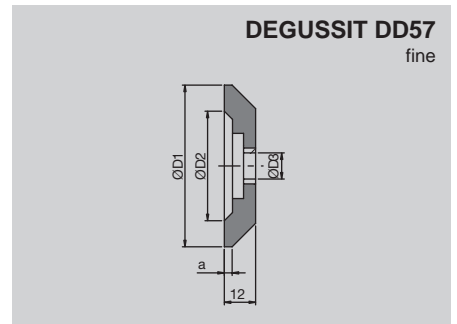

BURNISHING WHEELS

Ø D1	Ø D2	Ø D3	a	Product No.
70	60	10	8	931-41970-4
70	60	10	10	931-41970-5
70	60	10	12	931-41970-6
70	60	10	15	931-41970-7
80	60	10	8	931-41980-4
80	60	10	10	931-41980-5
80	60	10	12	931-41980-6
80	60	10	15	931-41980-7

Order-Related Product

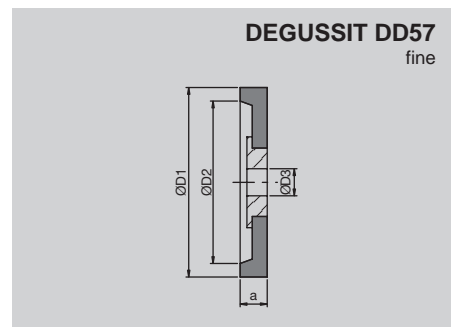

COMPETENCE PLUS RESPONSIBILITY

Our customers rightly expect first-class performance with lasting value. Besides the competence to achieve this, we also undertake the responsibility for it. Ask for the evidence: FRIATEC is the technological and market leader in ceramic materials for the 21st Century.



- | | |
|--|--|
| 01 Image-intensifier for radiology | 13 Guide strip for the printing industry |
| 02 X-Ray tube for radiology | 14 Isolator for the printing industry |
| 03 Pressure sensor for aerospace | 15 Square tubes for the printing industry |
| 04 Camera housing for aerospace | 16 Tubes, rods and capillaries for high temperature applications |
| 05 Accelerator tube for radiology | 17 Thermal protection tubes for the glass and metallurgical industries |
| 06 Feedthroughs for high-vacuum applications | 18 Crucibles and boats for industry and research |
| 07 High-voltage feedthroughs for vacuum technology | 19 FZY-probes for oxygen measurement in gases |
| 08 Insulating tubes for high-vacuum technology | 20 Dielectric elements for fuel cells |
| 09 High current feedthroughs for energy systems | 21 Dielectric elements for fuel cells |
| 10 Wafer carrier for the semiconductor industry | 22 Thermal protection tubes for high temperature applications |
| 11 Test plates for the semiconductor industry | 23 Shaping roller for the glass industry |
| 12 Sensor elements for the semiconductor industry | 24 Glow-block for heat treatment of lamp filaments |

Electrical Engineering
High Temperature Technology
Mechanical Engineering
Surface Finishing



- 25 Ozone generator for the semiconductor industry
- 26 Control discs for production and laboratory processes
- 27 Dosing pistons with control edge for the food-processing and pharmaceutical industries
- 28 Pump inserts for medical technology
- 29 Float body for flow-measurement in the chemical industry
- 30 Electrode holder for flow-measurement in the chemical industry
- 31 Flow meters for the food-processing industry
- 32 Welding pins for automotive-body manufacture
- 33 Centring pin for automotive-body manufacture
- 34 Metal-forming tools for automotive-body manufacture
- 35 Isolation shells for magnetically-coupled pump in the chemical industry
- 36 Pump impeller for the chemical industry
- 37 Stirrers for the chemical industry
- 38 High-pressure pump piston for the chemical industry
- 39 Adhesive nozzle for the paper industry
- 40 Valve disc for pulp-processing
- 41 Vacuum plate for paper-making
- 42 Protection tubes for the glass industry
- 43 Midget file for the glass-processing industry
- 44 Hand lappers for the glass-processing industry
- 45 Grinding wheel for the glass-processing industry
- 46 Grinding tools for metal working
- 47 Bench-stones for metal working
- 48 Mounted points for metal working